

TM 9-4910-706-14&P

---

**TECHNICAL MANUAL**

**OPERATOR'S, ORGANIZTIONAL, DIRECT SUPPORT  
AND GENERAL SUPPORT MAINTENANCE MANUAL  
INCLUDING REPAIR PARTS LIST**

**FOR**

**LEAK EXPOSER  
MODELS 17 AND 20  
(INLAND MANUFACTURING CO.)  
(NSN 4910-00-075-2394)**

---

**HEADQUARTERS, DEPARTMENT OF THE ARMY**

**MAY 1981**



Technical Manual }  
No. 9-4910-706-14&P }

HEADQUARTERS  
DEPARTMENT OF THE ARMY  
Washington, DC, 1 May 1981

**Operator's, Organizational, Direct Support  
and General Support Maintenance Manual  
Including Repair Parts List  
For  
LEAK EXPOSER  
MODELS 17 AND 20  
(NSN 4910-00-075-2394**

**REPORTING ERRORS AND RECOMMENDING IMPROVEMENTS**

You can help improve this manual. If you find any mistakes or if you know of a way to improve the procedures, please let us know. Mail your letter, DA Form 2028 (Recommended Changes to Publications and Blank Forms), or DA Form 2028-2, located in the back of this manual direct to: Commander, US Army Armament Materiel Readiness Command, ATTN: DRSAR-MAS, Rock Island, IL 61299. A reply will be furnished directly to you.

**NOTE**

This manual is for the purpose of identifying an authorized commercial manual for the use of the personnel to whom this leak exposer is issued.

Manufactured by: Inland Manufacturing Co.  
1108 Jackson Street  
Omaha, NE 68102

Procured under Contract No. DAAA09-79-F-4086

**This technical manual is an authentication of the manufacturers' commercial literature and does not conform with the format and content specified in AR 310-3, Military Publications. This technical manual does, however, contain available information that is essential to the operation and maintenance of the equipment.**

INSTRUCTIONS FOR REQUISITIONING PARTS

NOT IDENTIFIED BY NSN

When requisitioning parts not identified by National Stock Number, it is mandatory that the following information be furnished the supply officer,

- 1 - Manufacturer's Federal Supply Code Number - 92418
- 2 - Manufacturer's Part Number exactly as listed herein.
- 3 - Nomenclature exactly as listed herein, including dimensions, if necessary.
- 4 - Manufacturer's Model Number - Model 17 and 20
- 5 - Manufacturer's Serial Number (End Item)
- 6 - Any other information such as Type, Frame Number, and Electrical Characteristics, if applicable.
- 7 - If DD Form 1348 is used, fill in all blocks except 4, 5, 6, and Remarks field in accordance with AR 725-50.

Complete Form as Follows:

(a) In blocks 4, 5, 6, list manufacturer's Federal Supply Code Number - 92418 followed by a colon and manufacturer's Part Number for the repair part.

(b) Complete Remarks field as follows:

Noun: (nomenclature of repair part)  
For: NSN: 4910-00-075-2394  
Manufacturer: Inland Manufacturing Co.

Model : 17 and 20  
Serial : (of end item)

Any other pertinent information such as Frame Number, Type, Dimensions, etc.

OWNER'S MANUAL  
LEAK EXPOSER AND DRYER  
MODEL 17 AND 20  
TABLE OF CONTENTS

	<b>Page No.</b>
1. SPECIFICATIONS	2
2. INSTALLATION	3
3. INSTALLATION CHECKOUT	3
4. OPERATION	4
5. PREVENTATIVE MAINTENANCE	4
6. CORRECTIVE MAINTENANCE	5
7. PARTS LIST	7
8. EXPLODED VIEW	8
9. WIRING DIAGRAM	9

OWNER'S MANUAL

LEAK EXPOSER AND DRYER

MODELS 17 AND 20

Leak Exposer and Dryer will quickly evaporate all moisture from both inside and outside of radiators and heater cores. After vat cleaning and flushing, the radiator must be thoroughly dry inside before leak testing. Also after radiator is repaired, it should be dry before painting. The Leak Exposer substantially reduces the time required for natural drying.

This equipment is constructed of the highest quality material and is manufactured in accordance with strict quality assurance standards.

Your machine is equipped with a damper for regulating the amount of warm air to either the inside or outside of the unit to be dried. A burner and a forced draft blower control air temperature and velocity for maximum efficiency.

The information contained in this manual will help you take advantage of all the features built into your machine for increased production.

Please read the instructions carefully.

1.	SPECIFICATIONS	MODEL 17	MODEL 20
	Overall Dimensions	39" left to right 36" front to back 36" high	48" left to right 36" front to back 36" high
	Burner Capacity:	36,600 BTU/Hour	46,600 BTU/Hour
	Net Weight:	303 lbs.	340 lbs.
		BOTH UNITS	
	Electrical:	1/4 H.P. Motor 115/60/1	5.2 AMPS
	Burner Orifice Size:	7/64" for Natural Gas	5/64" for Bottled
	Gas (Water Column) Pressure:	4" Natural Gas	11" Bottled

NOTE : The following information and procedures apply to both the Model 17 and 20.

## 2. INSTALLATION

2.1. To facilitate installation, locate machine near gas, air and electrical outlets. Place unit approximately one foot from wall and level machine with spirit level.

2.1.1. Connect gas supply to 3/4" pipe connection located at rear of machine. When connecting to natural gas, use pipe size large enough to permit 4" of water column operating pressure. If machine is to be operated on bottled gas, use a regulator on the gas tank and operate on water column pressure of 11". Connect air to air blow gun on right side of unit. 3/8" copper tubing can be used with appropriate fittings.

NOTE : This machine is equipped with a gas pressure gauge located on front at control section. This pressure gauge indicates burner operating pressure and is calibrated to read pressure in inches of water column.

Operating gas pressure is set by adjusting shut-off petcock located in burner compartment.

Check and comply with local municipal safety codes when making installation.

2.1.2. After completing gas connections, check for leaks by using soap bubble test applied with a soapy brush on all fittings while system is under pressure.

2.1.3. Plug in power cord to 115 volt outlet. The power cord is provided with a third wire for grounding the cabinet in accordance with standard safety practices.

## 3. INSTALLATION CHECKOUT (Refer to Exploded View Drawing)

3.1. Light burner pilot light. Make sure Timer is in OFF position, and blower is stopped. Open gas shut-off cock. Turn pilot valve setting on Basoid Valve to highest position and hold down red plunger stem. Light pilot light and continue to hold down red plunger for at least 60 seconds while pilot light is burning. This heats the safety thermocouple which controls main gas supply to burner.

3.2. Light burner by turning on timer. Burner should light, blower motor should run and gas pressure gauge should indicate operating pressure. Check pressure gauge to make sure pressures are within operating safety ranges. Use 4" for natural gas and 11" for bottled.

3.3. If pressure exceeds these limits, adjust pressure by rotating shut-off gas cock until proper pressure is obtained.

CAUTION: Operating burner on gas pressures above designated values causes overheating of radiator and machine's blower. Lower pressures will result in inefficient operation.

- 3.4. Check operation of damper in warm air plenum. The damper is adjusted by damper wheel located at front of machine. Damper may be positioned to direct all warm air out through Air Deflector Plate for drying outside of radiator after painting. When Air Deflector Plate is closed, all air is directed out of hose for drying inside of radiator before leak testing.
- 3.5. Check operation of Timer. When Timer moves to zero, burner should go out and blower motor should stop. Check that pilot light is burning.

4. OPERATION

- 4.1. Your machine is now ready to use. After radiator has been vat cleaned, flush, wash and drain thoroughly. Paint and Flush Booth is recommended for this purpose. Use air blow gun to remove excess water from fins.
- 4.2. Cap filler neck of radiator with Cap, Catalog No. 2000 or 2001. Place radiator over top opening of Leak Exposer. Attach flexible hose to radiator inlet and leave outlet open.
- 4.3. Turn on Timer. Most radiators will dry in 15 minutes. Radiator will be dry when all moisture has disappeared from all openings. When radiator is completely dry inside, it is ready for leak testing.

5. PREVENTATIVE MAINTENANCE

- 5.1. Your Leak Exposer will last indefinitely if given proper maintenance.
- 5.2. Lubrication

5.2.1. Motor. Motors without oil cups are sealed bearing motors and require no lubrication.

Motors with oil cups have sleeve bearings which are lubricated by a reservoir filled with oil-saturated Permawick. Lubricate every six months with 3 or 4 drops of light mineral oil such as SAE 10W. DO NOT OVER OIL. EXCESS OIL WILL FLOW IN MOTOR WINDINGS.



- 5.3.1. Trash Screen. Periodically remove Air Deflector Plate in bottom of air funnel and clean.

## 5.4. Painting

- 5.4.1. Interior and exterior of the machine has been coated with Epoxy Red Oxide Metal Primer, Catalog No. 4016-P. Once a year or as needed, sand rusted areas, prime and refinish to prevent deterioration and to preserve an attractive appearance. The exterior top coat has a tough chemical resistant two-component catalyzed polyurethane safety orange (Cat. No. 4024). Clean and repaint surfaces as needed to preserve a good finish and an attractive appearance. Always prime bare metal.

## 6. CORRECTIVE MAINTENANCE

- 6.1. Pilot Light will not light. (Blower Off) Probable Causes.

- 6.1.1. Main gas line valve closed.
- 6.1.2. Gas shut-off cock on machine not open.
- 6.1.3. Baso Pilot Valve not open. Turn clockwise.
- 6.1.4. Red plunger button not fully depressed when lighting pilot.
- 6.1.5. Not enough time allowed after plunger button is depressed to bleed out air line.
- 6.1.6. Obstruction in pilot orifice or pilot burner. Remove and clean. If pilot still fails to light, replace Baso Valve.

- 6.2. Pilot will light but will not remain burning. (Blower Off) Probable Causes.

- 6.2.1. Red plunger button not depressed long enough after pilot is burning to permit thermocouple to heat and open automatic valve in Baso Valve.
- 6.2.2. Damaged or loose thermocouple lead connections at pilot burner. Replace if damaged.
- 6.2.3. Thermocouple probe bent away from heating flame of pilot.

- 6.3. Burner fails to ignite. (Blower on and Pilot burning). Probable Causes.

- 6.3.1. Air still in line to burner. Make sure pilot light is burning, then set time to maximum to bleed line.
- 6.3.2. Pilot nozzle out of alignment. Pilot nozzle should touch burner head so that pilot flame shoots through slot in steel plate at an angle. Loosen screw holding pilot and thermocouple assembly to burner and adjust.

- 6.3.3. Short in wiring or wrong voltage. Voltage is 115 volts. Check all contacts and wiring circuits.
- 6.3.4. Blown Fusetron. Replace.
- 6.3.5. Loose timer control knob preventing timer shaft from turning on.
- 6.3.6. Obstruction in burner orifice. Remove and clean. If burner still fails to ignite, replace Baso Valve.
- 6.4 Burner Fails to Extinguish When Timer Shuts Off. Probable Causes.
  - 6.4.1. Short circuit with limit controls in grounded side of circuit. Remove cause of short.
- 6.5. Motor and Blower fail to operate. Probable Causes.
  - 6.5.1. Power cord not plugged in.
  - 6.5.2. Blown fusetron. Replace.
  - 6.5.3. Short or loose connection in timer circuit. Check all contacts and circuit wiring.
  - 6.5.4. Loose timer knob preventing timer shaft from turning on.
  - 6.5.5. Motor burned out. Replace.
  - 6.5.6. Timer damaged or broken. Replace.

# PARTS LIST

TM 9-4910-706-14&P

MODEL 20 LEAK EXPOSER

TJL 10-13-71

REF. NO.	PART NO.	NO. REQ.	DESCRIPTION
1	W-0568	1	DAMPER WHEEL
2	S-0085	1	AIR FUNNEL
3	N-1120	1	TRASH SCREEN
4	S-0037	1	AIR DEFLECTOR PLATE
5	R-0622	2	AIR TRANSFER HOSE
6	N-1082	1	DAMPER CONTROL ROD
7	SP-0437	1	VENT PIPE ELBOW
8	SP-0446 -26	1	VENT PIPE TEE & DAMPER
9	E-0159	1	MOTOR
10	A-0712	1	BLOWER
11	G-1008	1	BURNER CHAMBER
12	S-0057	2	SCREEN
13	E-0125	1	POWER CORD
14	S-0085	1	DOOR PANEL
15	G-1032	1	THERMOCOUPLE LEAD
16	H-0980	1	COPPER TUBING W/ FITTINGS
17	G- 1007	1	PILOT ORIFICE
18	G-1007	1	BURNER PILOT ASSEMBLY
19	G-1066	1	BURNER & DISC
20	G-1026	1	BURNER ORIFICE
21	N-1187	1	COPPER TUBING W/ FITTINGS
22	S-0057	2	SCREEN
23	P-0384	1	GAS SHUT- OFF COCK
24	G-1040	1	BASO VALVE
25	S-0085	1	CABINET
26	G-1034	1	WATER PRESSURE GAUGE
27	H-0980	1	GAUGE TUBING & FITTINGS
28	E-0227	1	TIMER CONTROL KNOB
29	E-0227	1	TIMER CONTROL FACE COVER
30	E-0227	1	TIMER
31	SP-0435	4	VENT PIPE ELBOW
32	SP-0441	2	VENT PIPE SECTION
33	E-0148	1	FUSETRON

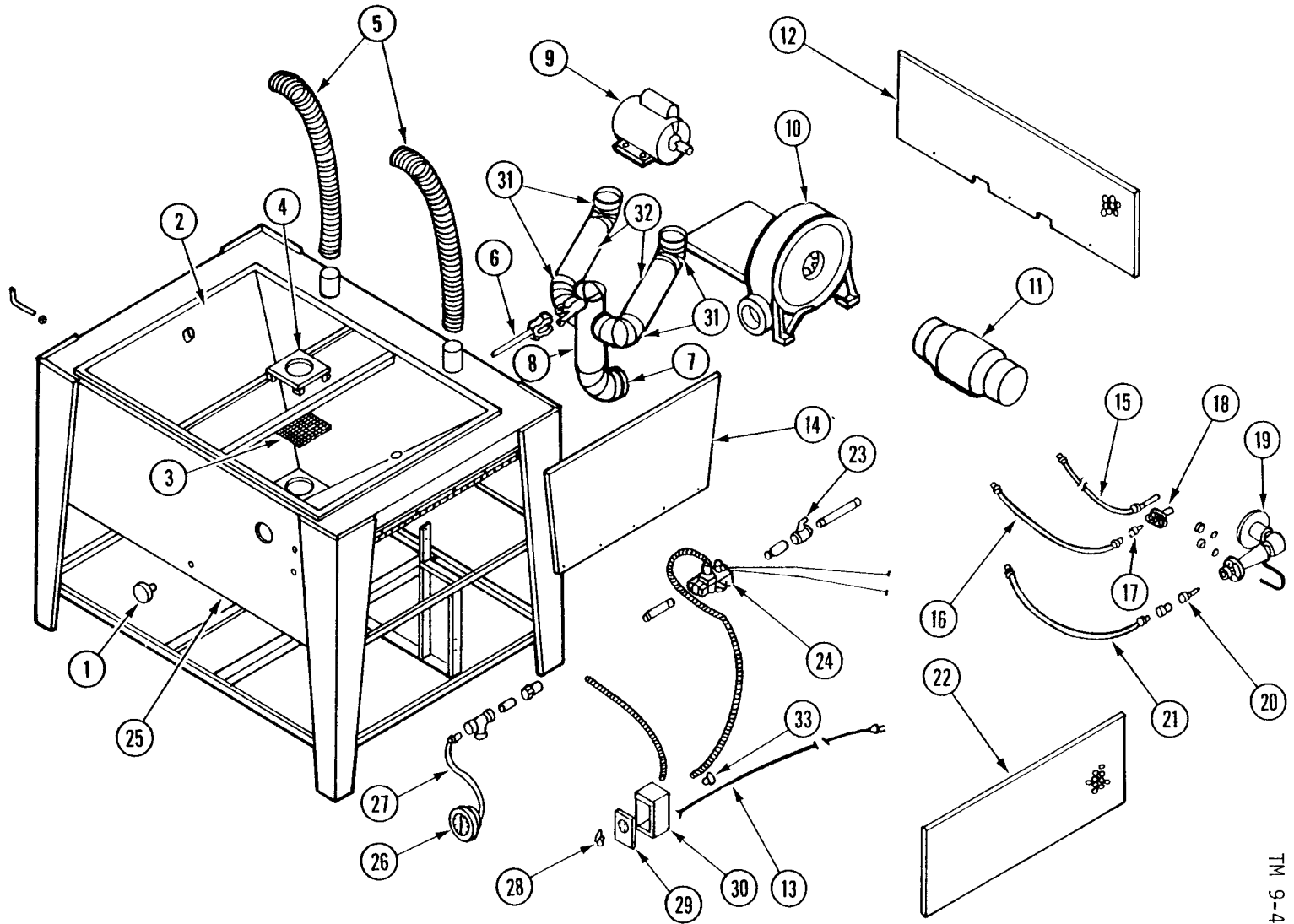

EXPLODED VIEW - MODEL 20 LEAK EXPOSER  
AND DRYER

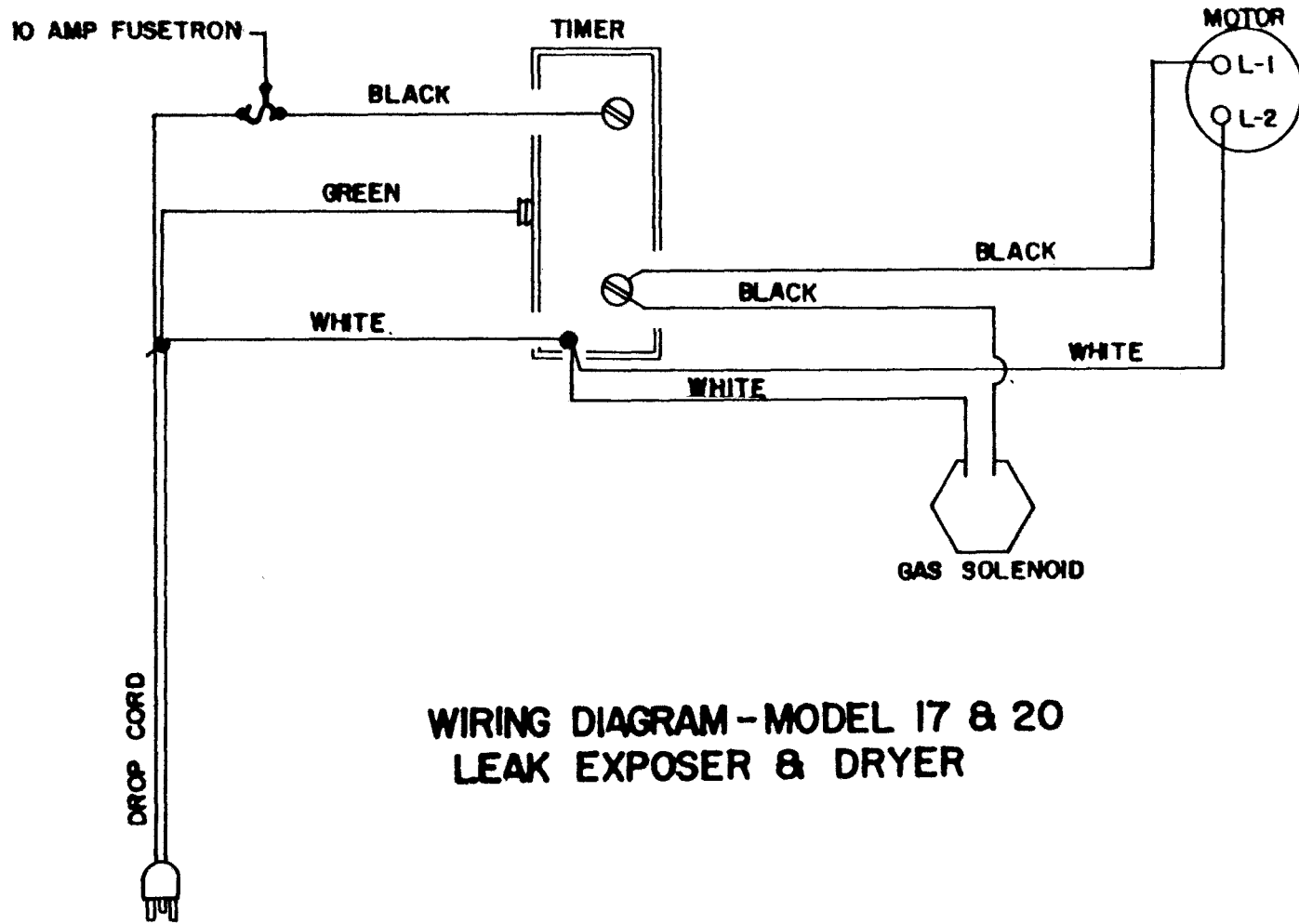

**WIRING DIAGRAM - MODEL 17 & 20  
LEAK EXPOSER & DRYER**

R. Nichols 10-23-72



By Order of the Secretary of the Army:

Official:

E. C. MEYER  
*General, United States Army*  
*Chief of Staff*

J, C. PENNINGTON  
*Major General, United States Army*  
*The Adjutant General*





RECOMMENDED CHANGES TO EQUIPMENT TECHNICAL PUBLICATIONS



THEN... JOT DOWN THE DOPE ABOUT IT ON THIS FORM, CAREFULLY TEAR IT OUT, FOLD IT AND DROP IT IN THE MAIL!

SOMETHING WRONG WITH THIS PUBLICATION?

FROM: (PRINT YOUR UNIT'S COMPLETE ADDRESS)

Your mailing address

DATE SENT

Date you filled out form.

PUBLICATION NUMBER

TM 9-XXXX-XXX-XX

PUBLICATION DATE

Date of TM

PUBLICATION TITLE

Title of TM

BE EXACT... PIN-POINT WHERE IT IS

PAGE NO	PARA-GRAPH	FIGURE NO	TABLE NO
400		183	
512		191	

IN THIS SPACE TELL WHAT IS WRONG AND WHAT SHOULD BE DONE ABOUT IT:

Change illustration Reason: Tube end shown assembled on wrong side of lever cam.

Figure 191, item 3 has the wrong NSN. Supply rejects orders for this item. The NSN shown here is not listed in the AMDF or the MCRL.

Please give us the correct NSN and P/N.

SAMPLE

PRINTED NAME, GRADE OR TITLE, AND TELEPHONE NUMBER

John Smith, S. SGT. 793/XXXX

SIGN HERE

*John Smith*

DA FORM 2028-2  
1 JUL 79

PREVIOUS EDITIONS ARE OBSOLETE.

U.S.—IF YOUR OUTFIT WANTS TO KNOW ABOUT YOUR RECOMMENDATION MAKE A CARBON COPY OF THIS AND GIVE IT TO YOUR HEADQUARTERS.

TEAR ALONG PERFORATED LINE

FILL IN YOUR  
UNIT'S ADDRESS

FOLD BACK

DEPARTMENT OF THE ARMY

\_\_\_\_\_  
\_\_\_\_\_

OFFICIAL BUSINESS  
PENALTY FOR PRIVATE USE \$300

POSTAGE AND FEES PAID  
DEPARTMENT OF THE ARMY  
DOD 314



TEAR ALONG PERFORATED LINE

Commander  
US Army Armament Materiel Readiness Command  
ATTN: DRSAR-MAS  
Rock Island, IL 61299

RECOMMENDED CHANGES TO EQUIPMENT TECHNICAL PUBLICATIONS



THEN... JOT DOWN THE DOPE ABOUT IT ON THIS FORM, CAREFULLY TEAR IT OUT, FOLD IT AND DROP IT IN THE MAIL!

**SOMETHING WRONG WITH THIS PUBLICATION?**

FROM: (PRINT YOUR UNIT'S COMPLETE ADDRESS)

---

DATE SENT

PUBLICATION NUMBER TM 9-4910-706-14&P	PUBLICATION DATE 1 May 1981	PUBLICATION TITLE Leak Exposer Models 17 and 20
--	--------------------------------	---

BE EXACT... PIN-POINT WHERE IT IS				IN THIS SPACE TELL WHAT IS WRONG AND WHAT SHOULD BE DONE ABOUT IT:
PAGE NO.	PARA-GRAPH	FIGURE NO.	TABLE NO.	

TEAR ALONG PERFORATED LINE

PRINTED NAME, GRADE OR TITLE, AND TELEPHONE NUMBER	SIGN HERE:
--	------------

FILL IN YOUR  
UNIT'S ADDRESS

FOLD BACK

DEPARTMENT OF THE ARMY

\_\_\_\_\_  
\_\_\_\_\_

OFFICIAL BUSINESS  
PENALTY FOR PRIVATE USE \$300

POSTAGE AND FEES PAID  
DEPARTMENT OF THE ARMY  
DOD 314



TEAR ALONG PERFORATED LINE

Commander  
US Army Armament Materiel Readiness Command  
ATTN: DRSAR-MAS  
Rock Island, IL 61299

RECOMMENDED CHANGES TO EQUIPMENT TECHNICAL PUBLICATIONS



THEN... JOT DOWN THE DOPE ABOUT IT ON THIS FORM. CAREFULLY TEAR IT OUT. FOLD IT AND DROP IT IN THE MAIL!

**SOMETHING WRONG WITH THIS PUBLICATION?**

FROM: (PRINT YOUR UNIT'S COMPLETE ADDRESS)

DATE SENT

PUBLICATION NUMBER

TM 9-4910-706-14&P

PUBLICATION DATE

1 May 81

PUBLICATION TITLE

Leak Exposer  
Models 17 and 20

BE EXACT... PIN-POINT WHERE IT IS

PAGE NO.	PARA-GRAPH	FIGURE NO.	TABLE NO.

IN THIS SPACE TELL WHAT IS WRONG AND WHAT SHOULD BE DONE ABOUT IT:

PRINTED NAME, GRADE OR TITLE, AND TELEPHONE NUMBER

SIGN HERE:

TEAR ALONG PERFORATED LINE

FILL IN YOUR  
UNIT'S ADDRESS

FOLD BACK

DEPARTMENT OF THE ARMY

OFFICIAL BUSINESS  
PENALTY FOR PRIVATE USE \$300

POSTAGE AND FEES PAID  
DEPARTMENT OF THE ARMY  
DOD 314



TEAR ALONG PERFORATED LINE

Commander  
US Army Armament Materiel Readiness Command  
ATTN: DRSAR-MAS  
Rock Island, IL 61299

RECOMMENDED CHANGES TO EQUIPMENT TECHNICAL PUBLICATIONS



THEN... JOT DOWN THE DOPE ABOUT IT ON THIS FORM, CAREFULLY TEAR IT OUT, FOLD IT AND DROP IT IN THE MAIL!

**SOMETHING WRONG WITH THIS PUBLICATION?**

FROM: (PRINT YOUR UNIT'S COMPLETE ADDRESS)

DATE SENT

PUBLICATION NUMBER

TM 9-4910-706-14&P

PUBLICATION DATE

1 May 1981

PUBLICATION TITLE

Leak Exposer  
Models 17 and 20

BE EXACT... PIN-POINT WHERE IT IS

PAGE NO	PARA-GRAPH	FIGURE NO	TABLE NO
---------	------------	-----------	----------

IN THIS SPACE TELL WHAT IS WRONG AND WHAT SHOULD BE DONE ABOUT IT:

TEAR ALONG PERFORATED LINE

PRINTED NAME, GRADE OR TITLE, AND TELEPHONE NUMBER

SIGN HERE:

FILL IN YOUR  
UNIT'S ADDRESS

FOLD BACK

DEPARTMENT OF THE ARMY

\_\_\_\_\_  
\_\_\_\_\_

OFFICIAL BUSINESS  
PENALTY FOR PRIVATE USE \$300

POSTAGE AND FEES PAID  
DEPARTMENT OF THE ARMY  
DOD 314



TEAR ALONG PERFORATED LINE

Commander  
US Army Armament Materiel Readiness Command  
ATTN: DRSAR-MAS  
Rock Island, IL 61299





**TM 9-4910-706-14&P**

**LEAK EXPOSER, MODELS 17 AND 20 — 1981**